

Repair instruction for

novopress

HYDRAULIC DRIVE UNITS HA1ES / HA2

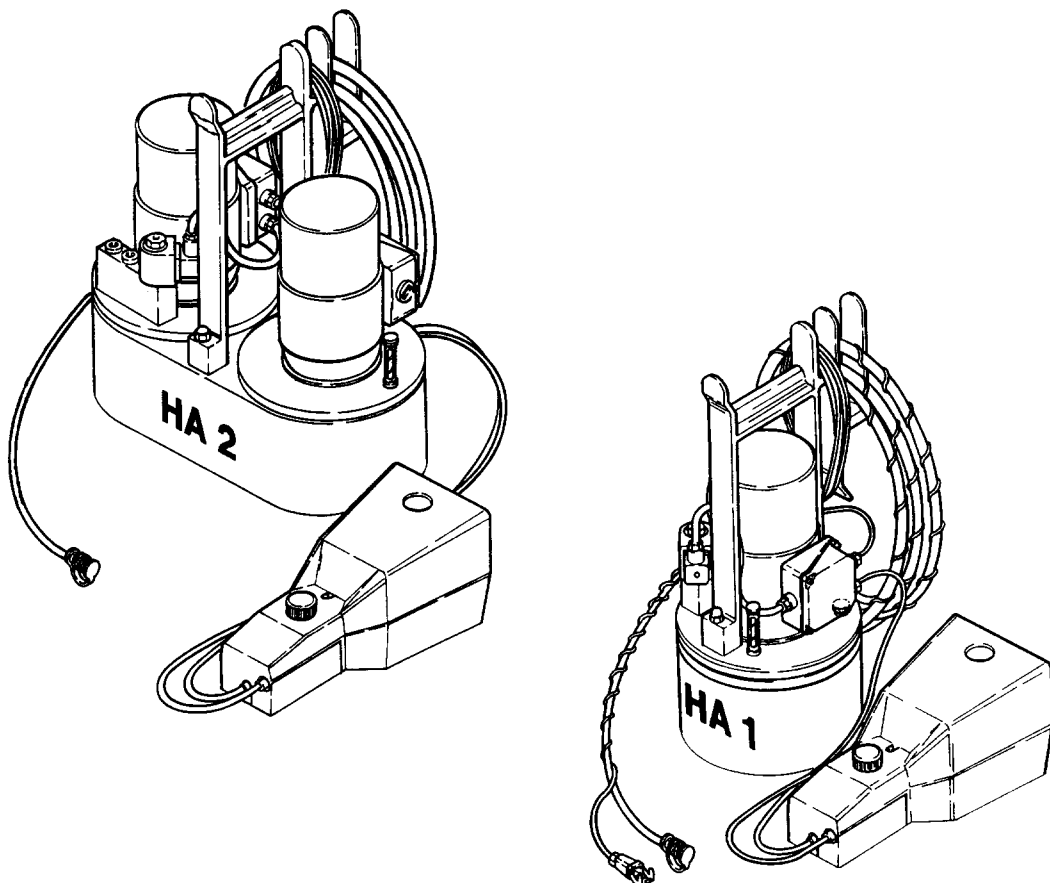

Contents list

	page
Safety rules	
General instructions	1
Operating faults and how to clear them	2
Replacement parts lists	
31070 HA1ES	4
31375 HA2	6
Module repair guide	
Replacing the clutch	8
Replacing the gear pump	8
Replacing the safety valve	8
Replacing the suction sieve	8
Replacing the venting valve	8
Replacing the drive motor	8
Module replacement parts lists	
30740 Safety valve	10
31311 Complete control block	11
31792 Complete motor (HA1ES)	12
4296 Complete motor (HA2)	14
Motor repair guide	
Replacing the fuses on the board	16
Replacing the board	16
Replacing the carbon brushes	16
Replacing the armature	16
Replacing the bearing	16
1302 Suction sieve	17
1532 Venting valve	18
1648 Sealing set for hydraulic drive hose coupling	19
1709 Clutch	19
31385 Oil level display	20
31620 Complete foot switch	21
Appendix	
Circuit diagram	
Hydraulics diagram	

General instructions

NOTE: (7) [31311] means:
 item 7 here, sealing screw
 module no. 31311 here, complete control block

There are versions of the hydraulic unit for 3 different voltages: 230V, 115V, 48V
 There are therefore 3 different versions of some components. They are distinguished by the code number (C/n).

To order, please find the appropriate order number and quote it.

Example: A 115V drive motor is required.

Item	C/n	Description	Order no.	Qty
1		drive motor 230V, 50/60 Hz	14225	1
	61	drive motor 115V, 50/60 Hz	14226	1
2		board for 230V	14208	1
	61	board for 115V	14227	1

Quote order number 14226.

WARNING! Disconnect the mains plug before starting maintenance work.

For repairs to electric motors, the high voltage tests according to VDE (= association of German electrical engineers) 0740 and CEE (= International Commission on Rules for the Approval of Electrical Equipment) publication 20 must be carried out.

Operating faults and how to clear them

Item	Fault	Cause	How to clear
1	Tool piston does not come out or not completely	Oil level too low	Top up oil.
		Magnet or directional valve does not work	Check electrical connections. Nut (2a) [31311] fastened too tightly. Loosen nut.
2	Tool piston comes out very slowly and does not give full power	Suction sieve (14) dirty	Proceed as described in items 4.1 to 4.2. Clean sieve washer (5) [1302].
		Gear pump defective	Replace gear pump.
3	Tool piston does not go back	Directional valve (2) [31311] stuck	Replace directional valve.
4	Drive unit does not start	No mains power	Check power supply.
		Mains plug not connected	Connect mains plug.
		Mains cable defective	Have mains cable replaced by specialist.
		Coding plug not connected	Connect coding plug to control line.
		Fuses on board defective	Replace fuses.
		Board defective	Replace board.
		Carbon brushes too short (shorter than 17 mm)	Replace carbon brushes.
		Armature defective	Replace armature.
		Electric motor defective	Replace electric motor.

REPLACEMENT PARTS LISTS

31070 HA1ES hydraulic drive unit

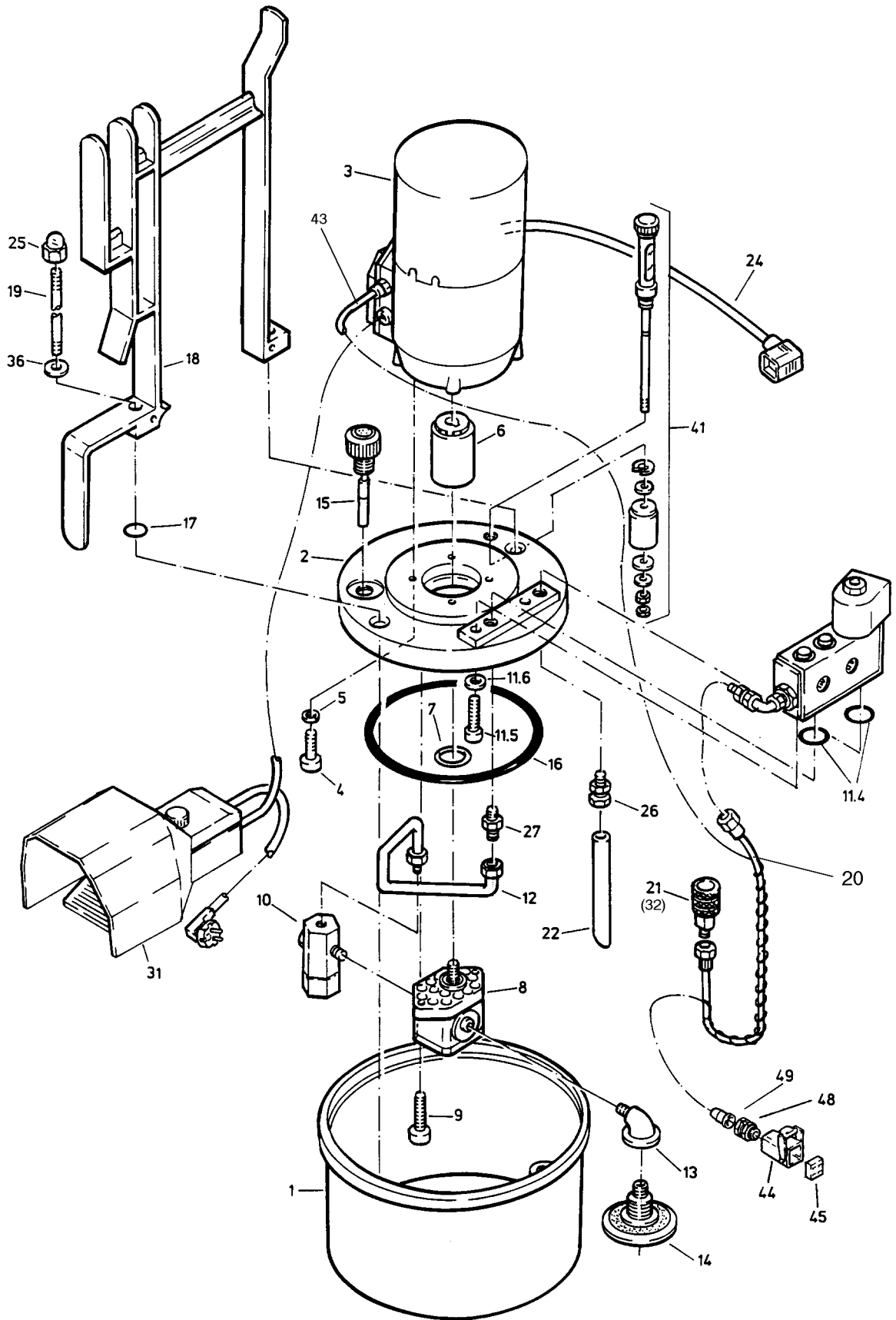

31070 HA1ES hydraulic drive unit

Item	Description	Order no.	Qty
1	oil reservoir	31182	1
2	oil reservoir cover	31411	1
3	complete motor	31792	1
4	cheese-head screw M5x25	11323	4
5	washer B5.3	11231	4
6	clutch	1709	1
7	O-ring	11006	1
8	complete gear pump	4298	1
9	cheese-head screw M6x20	11009	2
10	safety valve	30740	1
11	complete control block	31311	1
12	complete pressure pipe	31309	1
13	fitting	1410	1
14	suction sieve	1302	1
15	venting valve	1532	1
16	O-ring	13960	1
17	O-ring	11007	2
18	handle	3815	1
19	stud bolt	31356	2
20	high-pressure hose	4302	1
21	coupling sleeve	3719	1
22	backflow pipe	31075	1
24	control cable	30813	1
25	cap nut M8-6	14105	2
26	screw-in joint	14063	1
27	screw-in joint	14062	1
31	foot switch	31620	1
32	dust protection cap	1515	1
41	complete oil level display	31385	1
43	cable	14205	1
44	coupling housing	14206	1
45	plug cartridge	14207	1
46	cable tie	11778	11
47	coding plug	31843	1
48	cable strain relief	14270	1
49	anti-kink bush	14271	1
501	packing set for HA1	32534	1
502	packing set for coupling HA	1648	1

31375 HA2

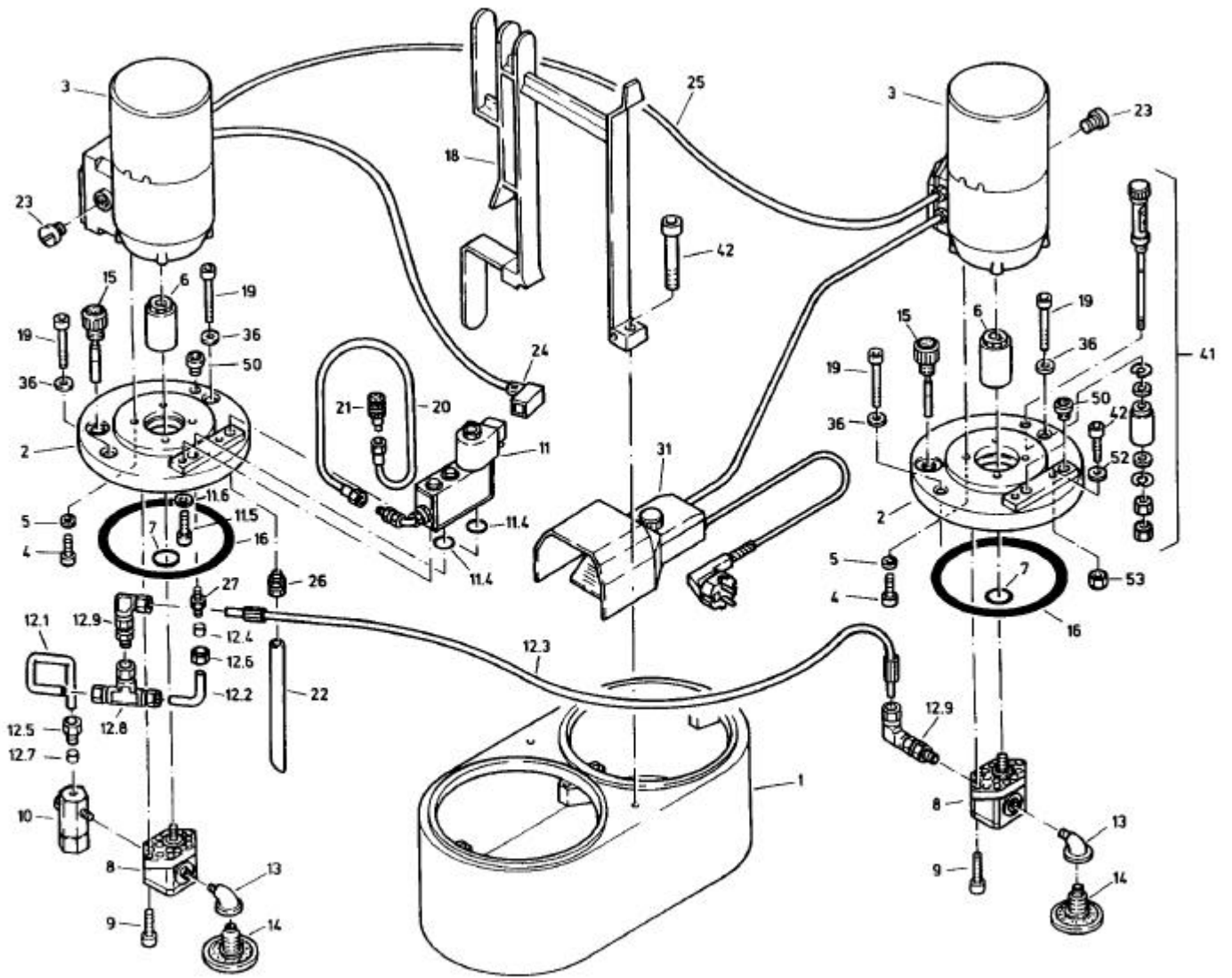

31375 HA2

Item	C/n	Description	Order no.	Qty
1		oil reservoir	31734	1
2		oil reservoir cover	31411	2
3		drive motor 230V	4296	2
	61	drive motor 115V	429651	2
4		cheese-head screw	11323	8
5		washer	11231	8
6		clutch	1709	2
7		O-ring	11006	2
8		complete gear pump	4298	2
9		cheese-head screw	11009	4
10		safety valve	30740	1
11		complete control block	31311	1
12		complete pressure pipe	31737	1
13		fitting	1410	2
14		suction sieve	1302	2
15		venting valve	1532	2
16		O-ring	13960	2
18		handle	3815	1
19		cheese-head screw M8x130	12268	4
20		high-pressure hose NW10x2500	4302	1
21		coupling sleeve	3719	1
22		backflow pipe	31075	1
23		blind plug PG11	11023	2
24		control cable 3	30813	1
25		cable	14204	1
26		screw-in joint	14063	1
27		screw-in joint	14062	1
31		complete foot switch	31620	1
32		dust protection cap	1515	1
36		washer A8.4	11174	4
41		complete oil level display	31385	1
42		cheese-head screw M8x35	11085	4
50		sealing screw	11284	3
52		washer B8.4	14066	2
53		nut M8	11367	2
501		packing set for HA2	32537	1
502		packing set for coupling HA	1648	1

MODULE REPAIR GUIDE

- 1. Replacing the clutch (6), order no. 1709** **-DISCONNECT MAINS PLUG-**
 - 1.1 Unscrew two cap nuts (25).
 - 1.2 Remove handle (18) from 31070 HA1ES drive unit.
Not required for 31375 HA2 drive unit.
 - 1.3 Remove complete oil reservoir cover (2) with drive motor (3) from oil reservoir (1).
 - 1.4 Unscrew four screws (4).
 - 1.5 Lift drive motor (3) from oil reservoir cover (2).
 - 1.6 Replace the clutch (6).

- 2. Replacing the gear pump (8), order no. 4298.** **-DISCONNECT MAINS PLUG-**
 - 2.1 Proceed as described in 1.1 to 1.3.
 - 2.2 Loosen the pressure pipe (12) on the control block (11).
 - 2.3 Unscrew the hexagonal hollow bolt, SW14, from the safety valve (10).
 - 2.4 Swivel the safety valve (10) with the pressure pipe (12) to the side.
 - 2.5 Unscrew two screws (9) and remove the gear pump (8).
 - 2.6 Unscrew cogwheel 1 (1) [1709] from the gear pump.
 - 2.7 Unscrew the suction sieve (14) and fitting (13) from the gear pump.
 - 2.8 Replace the gear pump (8).

- 3. Replacing the safety valve (10), order no. 30740** **-DISCONNECT MAINS PLUG-**
 - 3.1 Proceed as described in 1.1 to 1.3.
 - 3.2 Unscrew the pressure pipe (12) from the safety valve (10).
 - 3.3 Unscrew the hexagonal hollow bolt, SW14, from the safety valve (10).
 - 3.4 Replace the safety valve (10).
 - 3.5 When fitting the safety valve (10), do not forget the USIT rings.

- 4. Replacing the suction sieve (14), order no. 1302** **-DISCONNECT MAINS PLUG-**
 - 4.1 Proceed as described in 1.1 to 1.3.
 - 4.2 Unscrew the hexagonal hollow bolt (1) [1302], SW14.
 - 4.3 Replace the suction sieve (14).

- 5. Replacing the venting valve (15), order no. 1532** **-DISCONNECT MAINS PLUG-**
 - 5.1 Unscrew the sealing screw (1) [1532].
 - 5.2 Replace the venting valve (15).

- 6. Replacing the drive motor (3).** **-DISCONNECT MAINS PLUG-**
 - 6.1 Proceed as described in 1.1 to 1.5.
 - 6.2 Replace the drive motor (3).

MODULES Replacement parts lists

30740 Safety valve

Item	Description	Order no.	Qty
1	valve housing	30821	1
2	piston	30822	1
3	hollow bolt	30823	1
4	seal	30808	1
5	pressure spring	14084	1
6	Usit ring	11013	2
7	ball 7	11051	1
8	locking screw	31659	1
9	setscrew	11348	1
10	hexagonal nut M5	11065	1

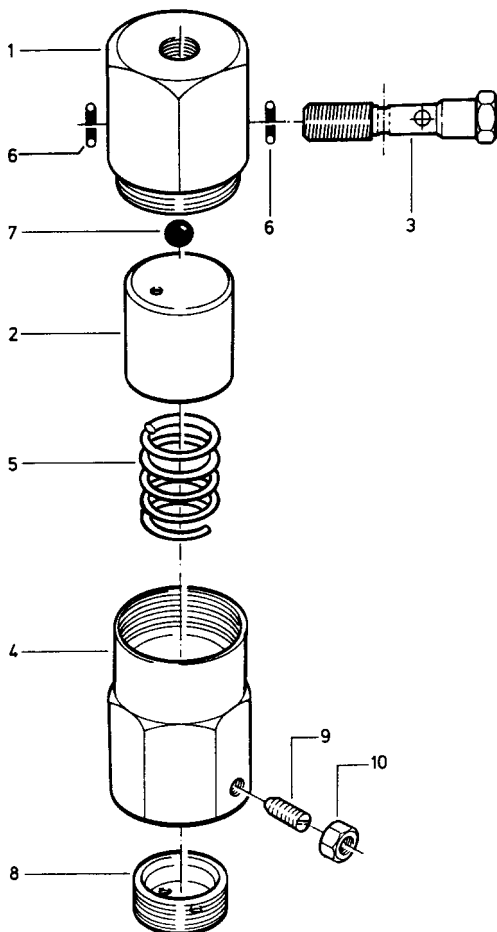

DISCONNECT MAINS PLUG!

Setting the safety valve (increasing the pressure)

1. Loosen the nut (10).
2. Loosen the screw (9).
1. Tighten the locking screw (8) by half a turn.
Rule: Tightening the locking screw (8) by half a turn results in a pressure increase of about 3-4 bar.

Note!

The locking screw (8) must not be screwed into the seal (4) by more than 6 mm!

2. Test the pressure of the hydraulic assembly (maximum 150 bar).
3. Repeat from 3 if required.
4. Tighten screw (9).
5. Tighten nut (10).

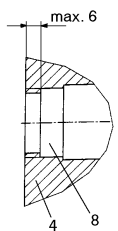

Notes for disassembly

Warning! Parts are under spring pressure.

Notes for assembly

During assembly, care must be taken that **the same ball (7) is always fitted**, since otherwise the cut-off pressure is changed.

31311 Complete control block

Item	C/n	Description	Order no.	Qty
1		control block	31301	1
2		2/2 directional valve	14042	1
3		magnet 230V, 50/60Hz	14041	1
	61	magnet 115V, 50/60Hz	14043	1
	155	magnet 48V DC	14047	1
4		O-ring	14065	2
5		cheese-head screw M8x35	11086	2
6		washer B8.4	14066	2
7		sealing screw	14060	2
9		screw-in joint	13376	1
23		threaded elbow joint	13414	1

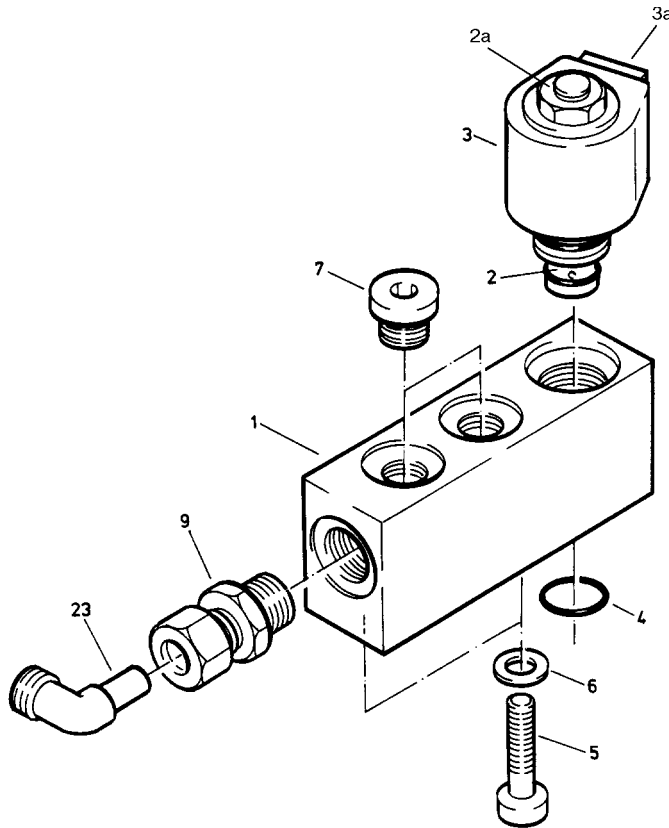

Replacing the directional valve (2) and magnet (3)

DISCONNECT MAINS PLUG!

- 1 Remove plug (3a) from magnet (3).
- 2 Unscrew nut (2a), SW 19.
- 3 Remove magnet (3).
- 4 Unscrew directional valve (2) (SW 1").

During assembly, screw nut (2a) so that the magnet can still just be moved.

31792 Complete motor (HA1ES)

Item	C/n	Description	Order no.	Qty
1		drive motor 230V, 50/60 Hz	14225	1
	61	drive motor 115V, 50/60 Hz	14226	1
2		board for 230V	14208	1
	61	board for 115V	14227	1
3		distance bolt	14228	1
4		hexagonal nut M3	13247	2
5		serrated lock washer	14215	6
7		hexagonal nut M3	14511	2
501		set of 2 carbon brushes	2899	1
502		armature for 230V	4301	1
	61	armature for 115V	430161	1
506		carbon brush holder	11707	2
507		interference filter for 230V	14241	1
	61	capacitor interference filter for 115V	12036	1
508	61	radio interference suppression coil for 115V	12256	1
512		complete terminal box	14735	1
513		protective cover	12133	1
515		lower ball bearing	11735	1
516		upper ball bearing	11736	1
519		bearing cover	13465	1

Note:

Item 508-61 is only fitted in motors for 115V.

31792 Complete motor (HA1ES)

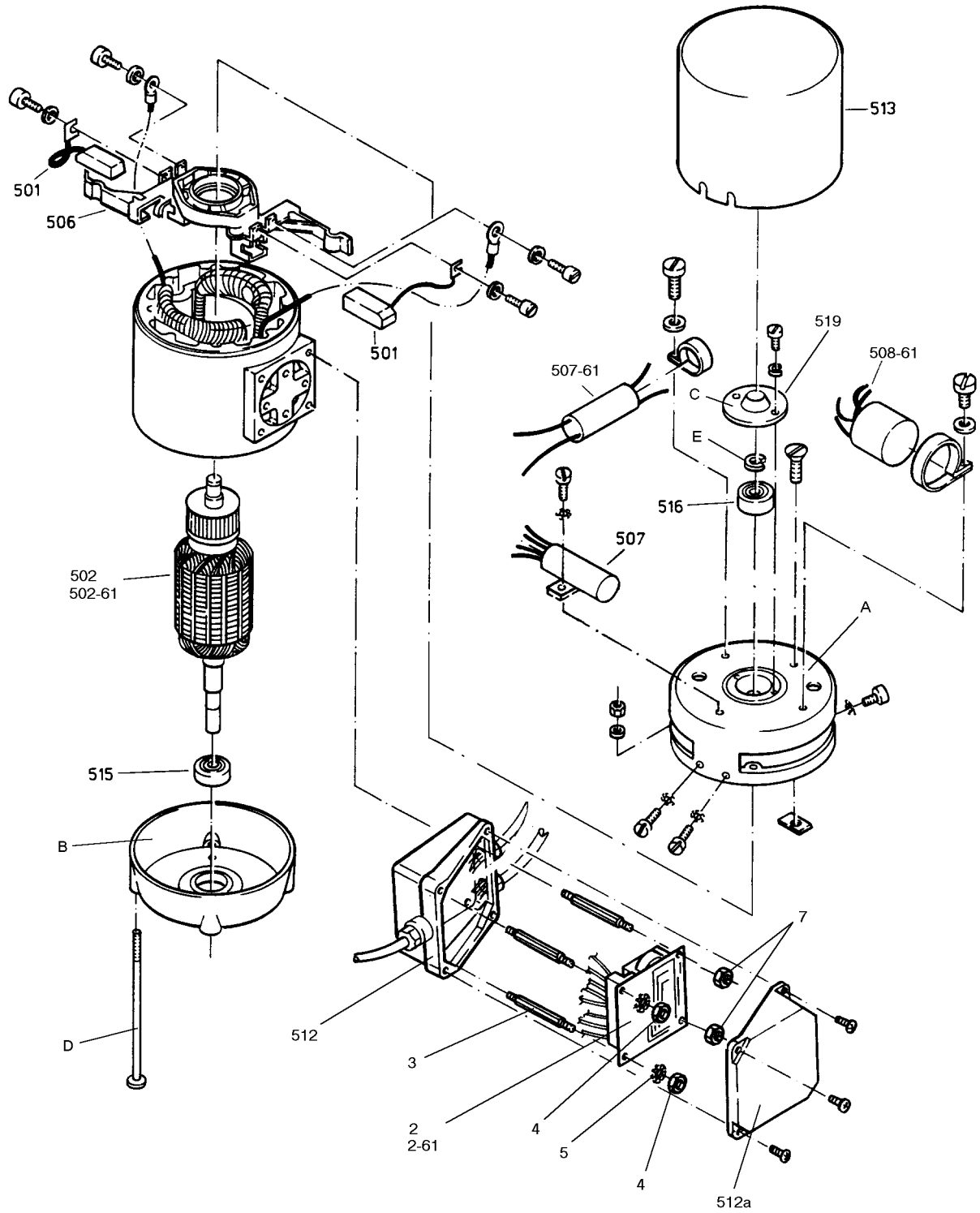
**Note**

507-61 means: item 507 with code number 61

4296 Complete motor (HA2)

Item	C/n	Description	Order no.	Qty
501		set of 2 carbon brushes	2899	1
502		armature for 230V	4301	1
	61	armature for 115V	430161	1
506		carbon brush holder	11707	2
507		interference filter for 230V	14241	1
	61	capacitor interference filter for 115V	12036	1
508	61	radio interference suppression coil for 115V	12256	1
512		complete terminal box	11902	1
513		protective cover	12133	1
514		terminal board	11516	1
515		lower ball bearing	11735	1
516		upper ball bearing	11736	1
519		bearing cover	13465	1

Note:

Item 508-61 is only fitted in motors for 115V.

4296 Complete motor (HA2)

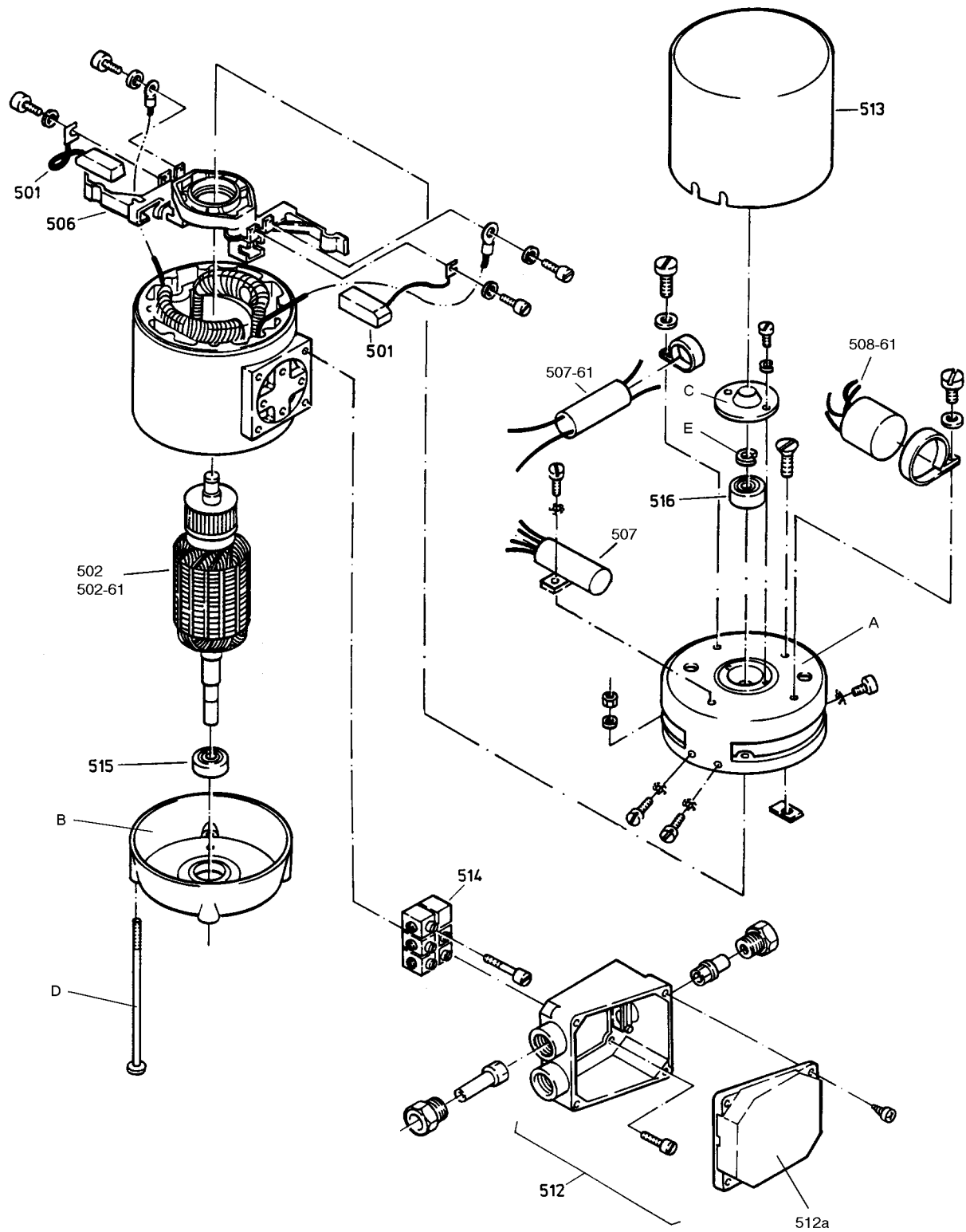
**Note**

507-61 means: item 507 with code number 61

MOTOR REPAIR GUIDE**DISCONNECT MAINS PLUG!****1. Replacing the fuses (100 mA glass bulb fuses) on the board**

- 1.1 Unscrew the terminal box cover (512a).
- 1.2 Unscrew the metal nuts (4).
- 1.3 Unscrew the plastic nuts (7).
- 1.4 Pull the board out.
- 1.5 Open the fuse holder (1).
- 1.6 Replace the fuses (100 mA glass bulb fuses).

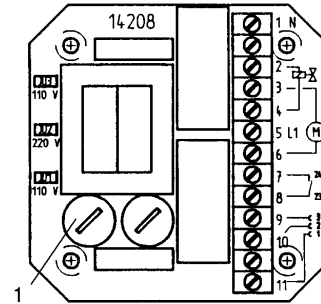
**2. Replacing the board (2)**

- 2.1 Proceed as described in 1.1 to 1.4.
- 2.2 Connect the connecting wires from the old board to the new board in numerical sequence.
- 2.3 Insert the new board carefully. Take care that no wires are pinched.
- 2.4 Fasten the board. Be careful of the arrangement of the nuts and serrated lock washers.
- 2.5 Put the terminal box cover (512a) on and screw it tight.

3. Replacing the set of 2 carbon brushes, order no. 2899.

- 3.1 Remove the protective hood (513).
- 3.2 Unscrew the carbon brushes (501) from the carbon brush holder (506).
- 3.3 Replace the carbon brush (501).

4. Replacing the armature (502), order no. 4301.

- 4.1 Remove the protective hood (513).
- 4.2 Unscrew the carbon brushes (501) from the carbon brush holder (506) and pull them out.
- 4.3 Remove the bearing cover (C) and shaft securing ring (E).
- 4.4 Loosen four screws (D) and push the armature (502) out from the collector side.
- 4.5 Push the armature (502) out of the bearing cover (B).
- 4.6 Replace the armature (502).

5. Replacing the bearing (516), order no. 11736.

- 5.1 Proceed as described in 4.1 to 4.4.
- 5.2 Push the bearing (516) out of the end plate (A).
- 5.3 Replace the bearing (516).

6. Replacing the bearing (515), order no. 11735.

- 6.1 Proceed as described in 4.1 to 4.5.
- 6.2 Pull the bearing (515) from the armature shaft.
- 6.3 Replace the bearing (515).

1302 Suction sieve

Item	Description	Order no.	Qty
1	hollow bolt	11035	1
2	washer	11036	2
3	washer	11037	5
4	sieve washer	11034	1

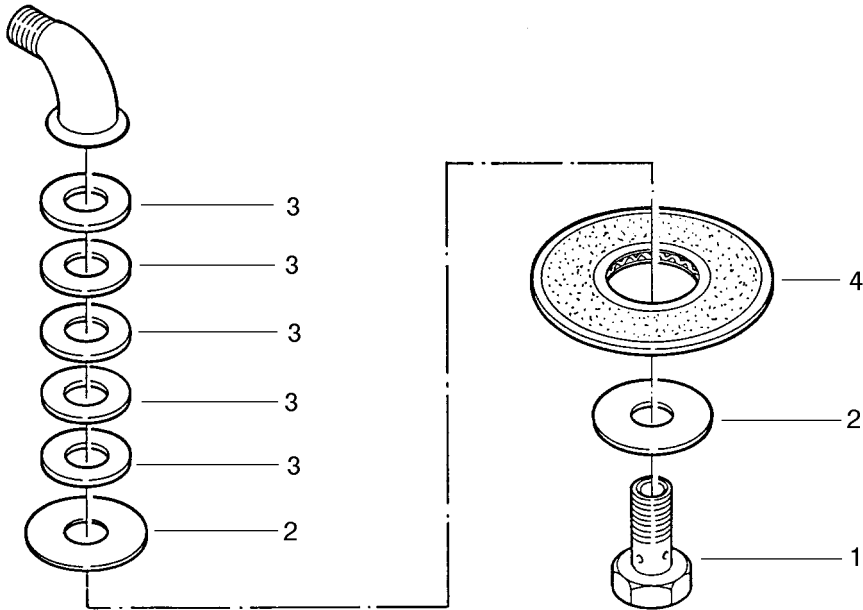

1532 Venting valve

Item	Description	Order no.	Qty
1	sealing screw	1464	1
2	pendulum	1465	1
3	filter	11028	1
4	adjusting washer	11029	1
5	securing ring	11030	1
6	O-ring	11007	1
7	O-ring	11033	1
8	snap ring	11031	1

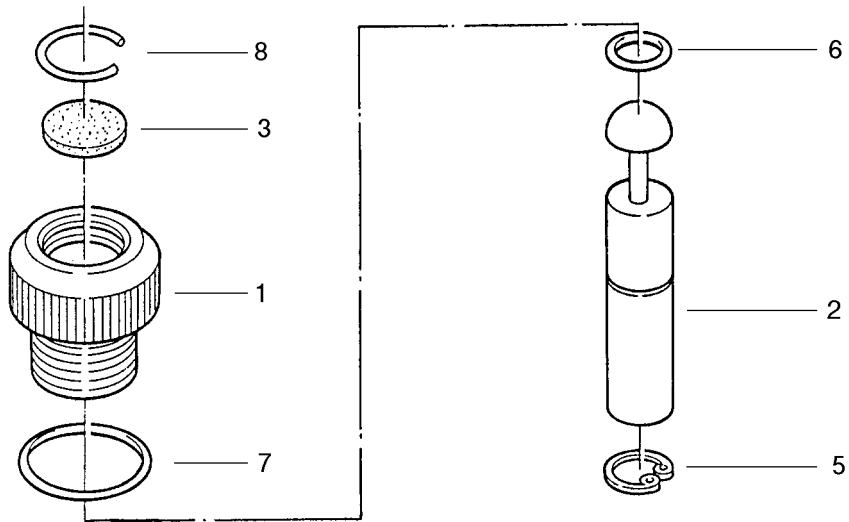

1648 Sealing set for hydraulic drive hose coupling

Item	Description	Order no.	Qty
1	O-ring	12097	1
2	back ring	12098	1

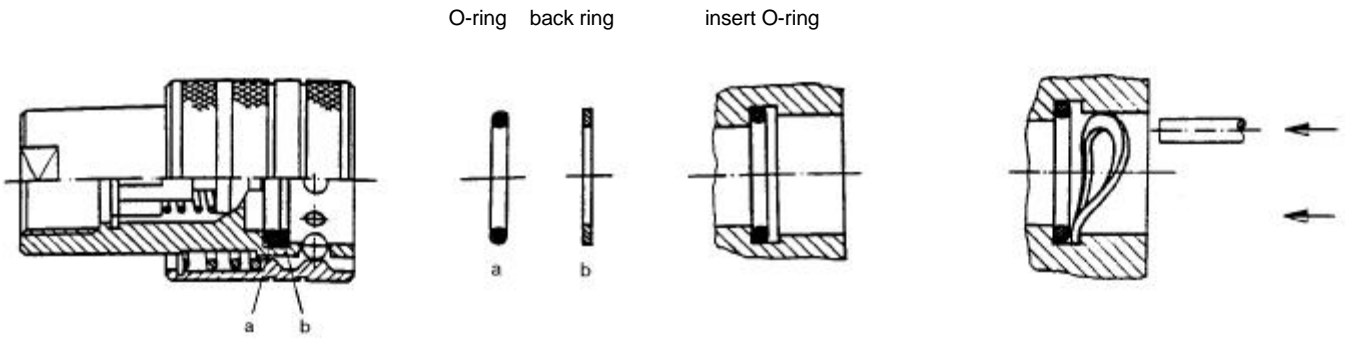

Push the back ring in all around with a blunt object, as far as it will go.

1709 Clutch

Item	Description	Order no.	Qty
1	cogwheel	1609	1
2	cogwheel	1610	1
3	sleeve	1611	1

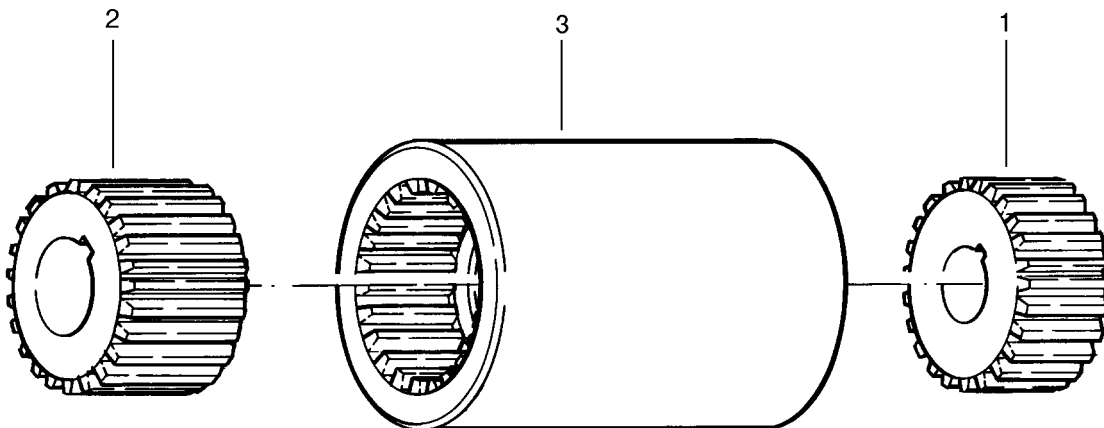

31385 Oil level display

Item	Description	Order no.	Qty
1	oil level display	14108	1
2	printed glass tube	31419	1
3	flat seal	14191	1
4	rubber seal	14665	1
5	cover	14190	1
6	threaded rod	31383	1
7	securing washer	11873	1
8	plastic float	14109	1
9	washer A3.2	13188	2
10	washer 5.3	11083	1
11	hexagonal nut M3	14107	3

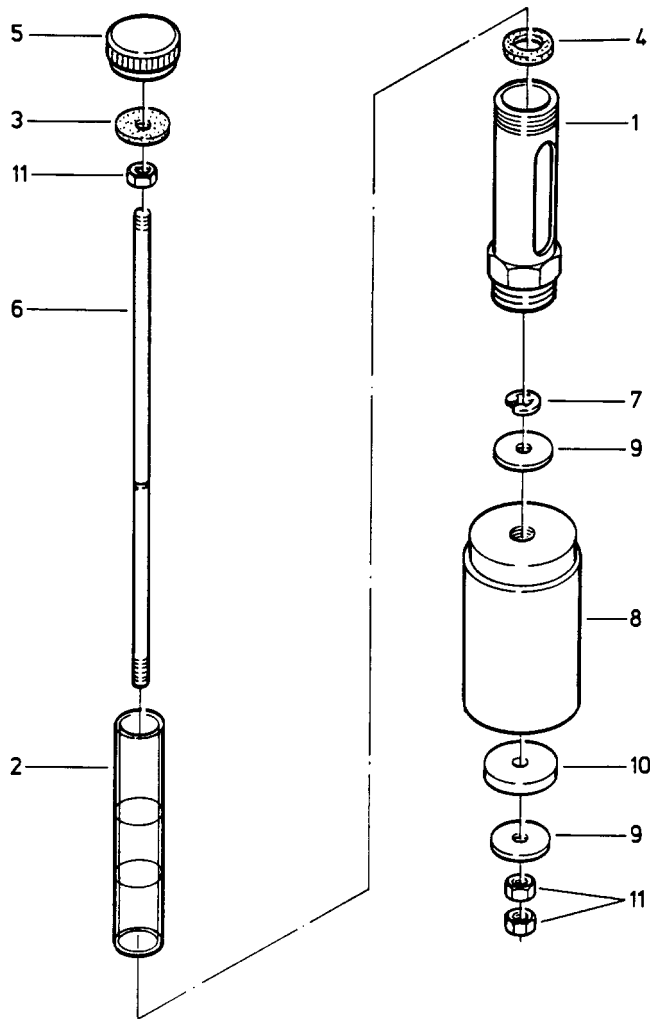

31620 Complete foot switch

Item	Description	Order no.	Qty
1	foot switch	14175	1
2	cable screwed joint	14176	1
3	cable screwed joint	14177	1
4	connecting cable	4297	1
5	cable	14209	1
501	switching contact	14664	2

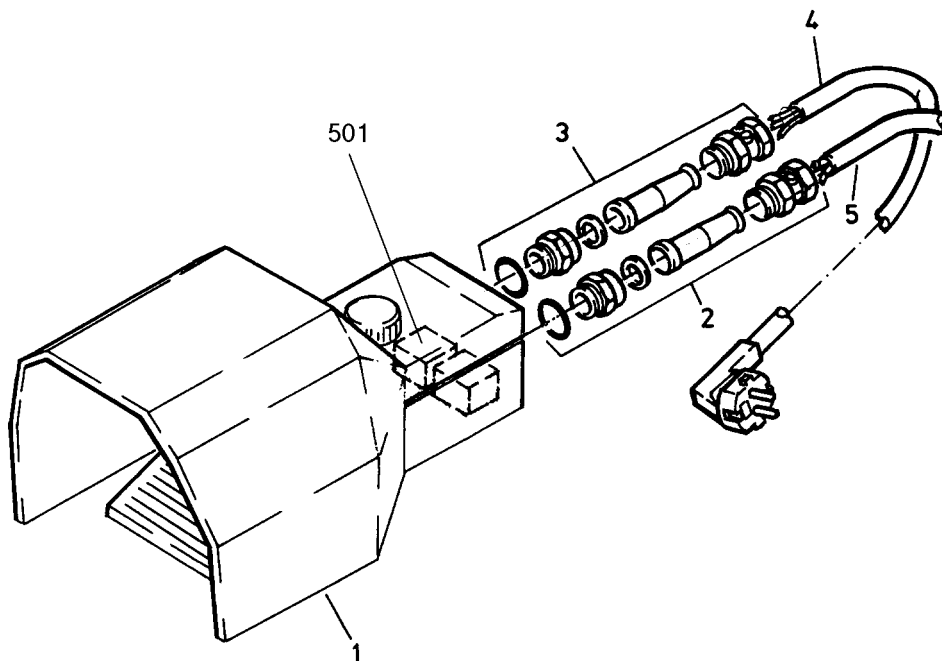

Repairs and service

novopress

Street address:
Scharnhorststrasse 1
D-41460 Neuss
Germany

Postal address:
Postfach 101163
D-41411 Neuss
Germany
Telex 8 518 015
Tel. (+49)2131 / 2880
Fax (+49)2131 / 28855