

H7105

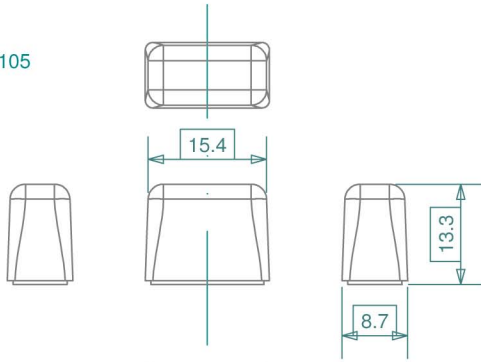

3D not to scale

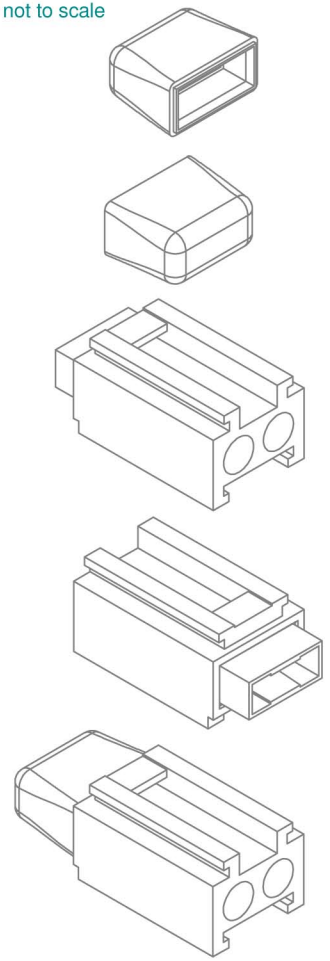

H7101

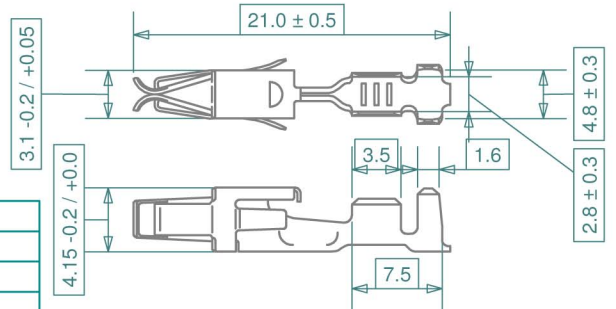
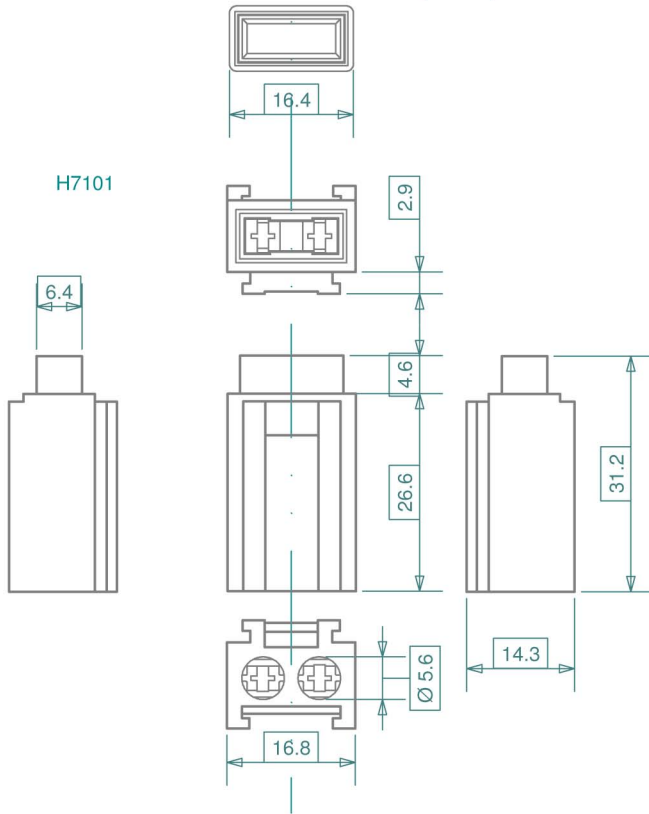

Contact scale 2 : 1

Seal scale 3 : 1

ref.	Description
H7101	fuse holder body, PA 66 GF25, black
H7105	cover PP, for use on FH H7120 series, translucent
H7120 *	FH miniOTO assembled, 2,5mm <sup>2</sup> red wire 1p, no cover *
H1007	mounting bracket steel, for holders H1010, H7120 series
CCS710FR	contact 1.5-2.5mm <sup>2</sup> , seal type, reeled
CCS710FL	contact 1.5-2.5mm <sup>2</sup> , seal type, loose
S561216	cable seal HD 5.6mm, green, cable diam. 1.2 - 1.6mm
S561724	cable seal HD 5.6mm, yellow, cable diam. 1.7 - 2.4mm
S562533	cable seal HD 5.6mm, red, cable diam. 2.5 - 3.3mm
CCX705FL	contact 0.5-1.0mm <sup>2</sup> , loose
CCX710FL	contact 1.5-2.5mm <sup>2</sup> , loose

\* see drawing "H7120 drawing 1" for assembled version

Revisions			Date	Appr.
Date	Type	Drawn	Date	Appr.
a 02/11	updated dimensions	Checked	09/17	BE
b 08/11	updated dimensions	Standards		
c 08/11	added contact & seal part numbers	Approved	09/17	AdH
d 09/16	added contact part numbers			
e 09/17	removed obsolete part number			



Scale	1 : 1	Title	H7100 series 1 pos miniOTO FH
Projection		Drawing type	schematic
Tolerance	± 0.2 mm unless otherwise noted	Drawing number	H7100 drawing 1
		Sheet	1 of 1
		Layers / Sheet	0 1 2 6 8 9 11 Sheet 01